





SBEV-RIN32M4CL3 Rev2.00

SCHEMATIC Revision 1.00 = PWB Revision 1.00

Date	Rev	Page	Changes	変更作業者
2021/09/22	2.00	2	Correct pin assignment from Y12 to U17 of U1A.	伊藤

注意事項

*印はGNDガード  *印は等長配線  *印はインピーダンス指定 

*印は未実装 

Rev1.00 205 Parts, 25 Library Parts, 151 Nets, 771 Pins

TOP			
Title			
SBEV-RIN32M4CL3			
Size	Document Number		Rev
A3	301251001		1.00
Date:	Tuesday, June 29, 2021	Sheet	1 of 24

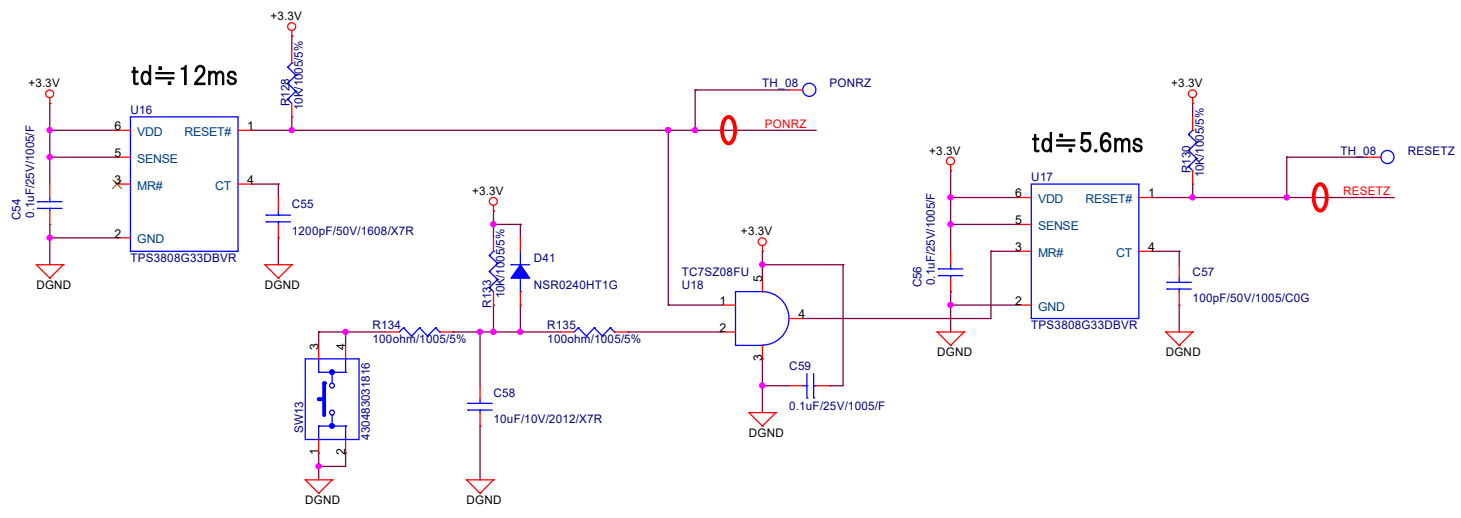
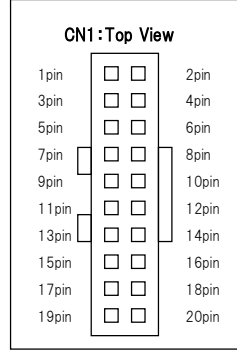
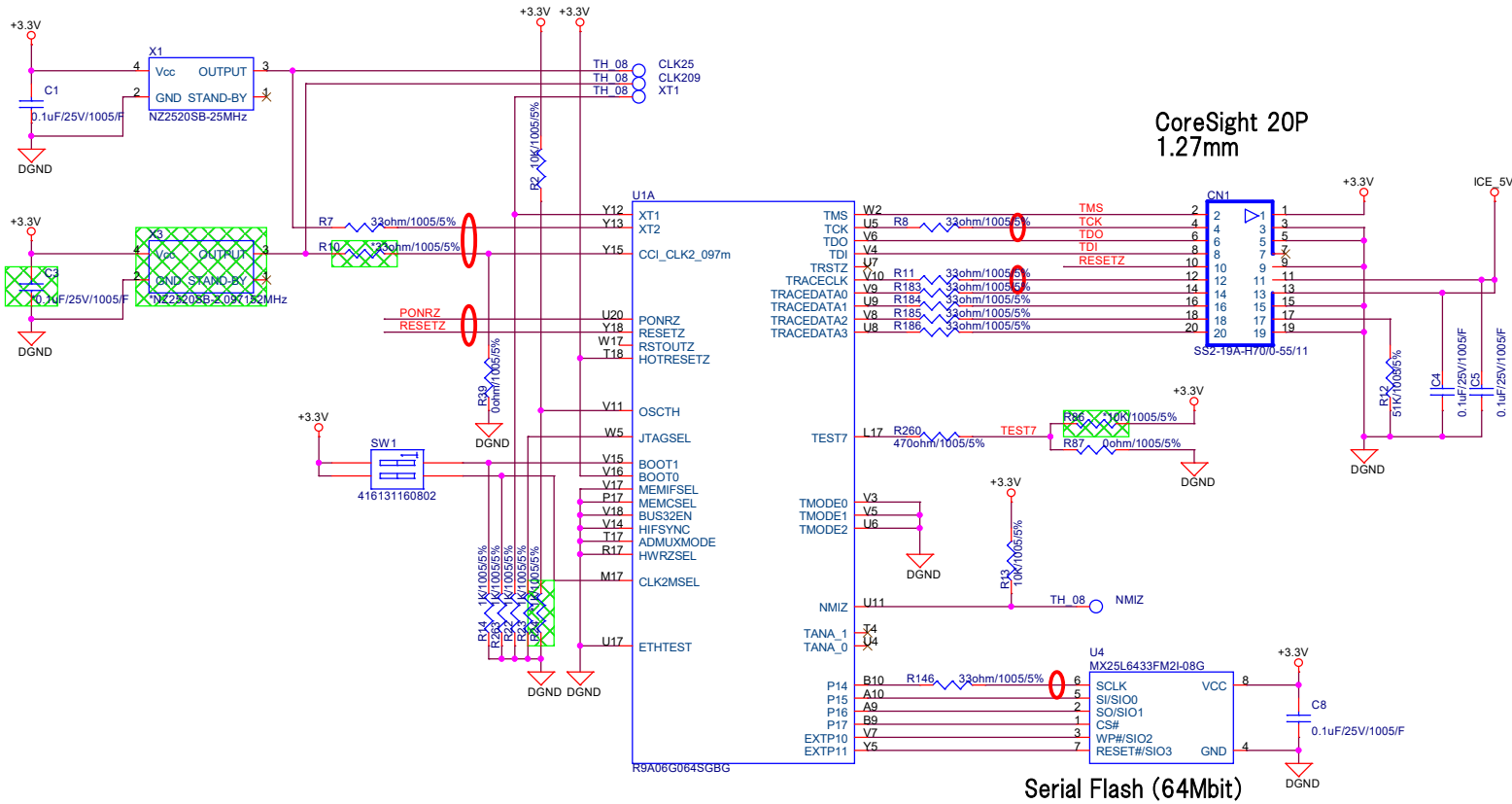

CPU		
Title	SBEV-RIN32M4CL3	
Size	Document Number	Rev
A3	301251001	1.00
Date:	Tuesday, June 29, 2021	Sheet 4 of 24

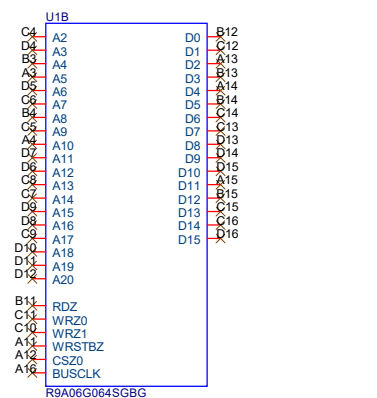
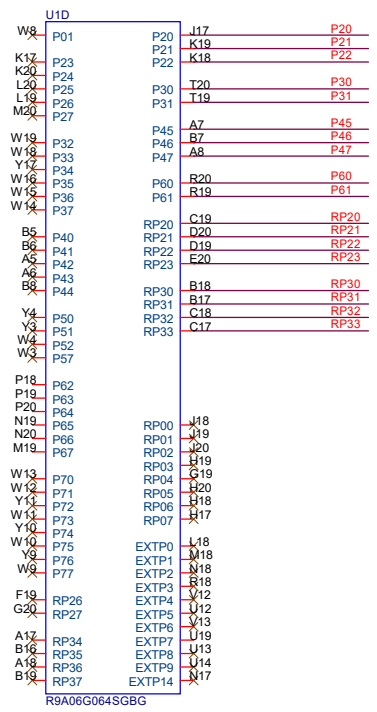

UART

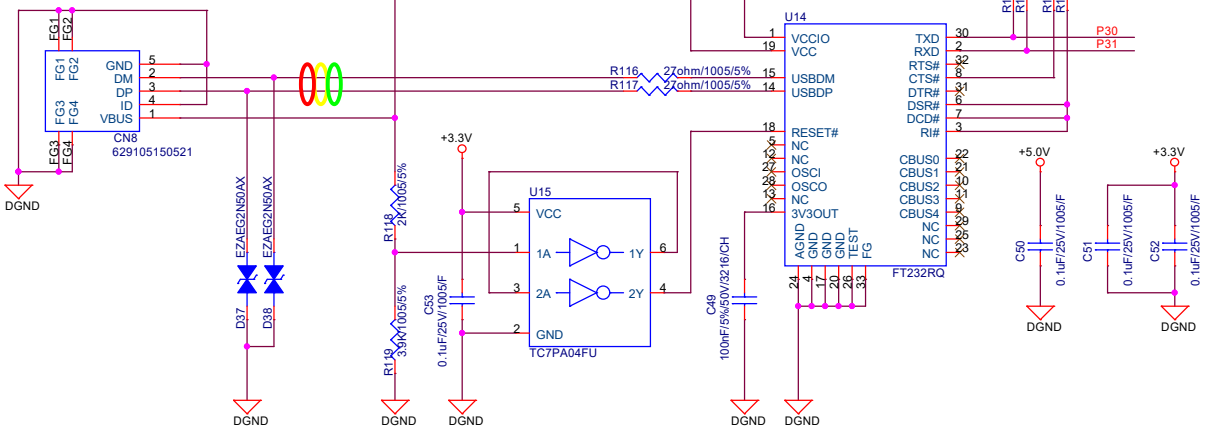

GPIO(Input)

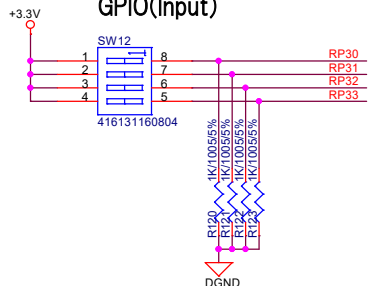

GPIO(Output)

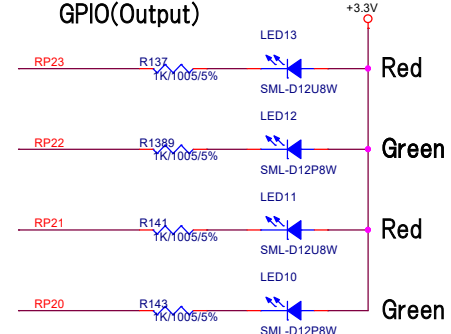

I2C

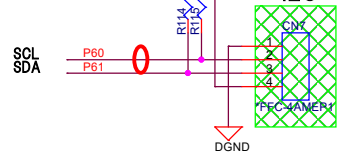

CSI

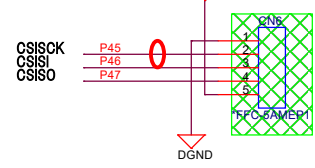

RS-485

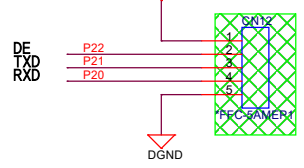

IO		
Title	SBEV-RIN32M4CL3	
Size	Document Number	Rev
A3	301251001	1.00
Date:	Tuesday, June 29, 2021	Sheet 5 of 24

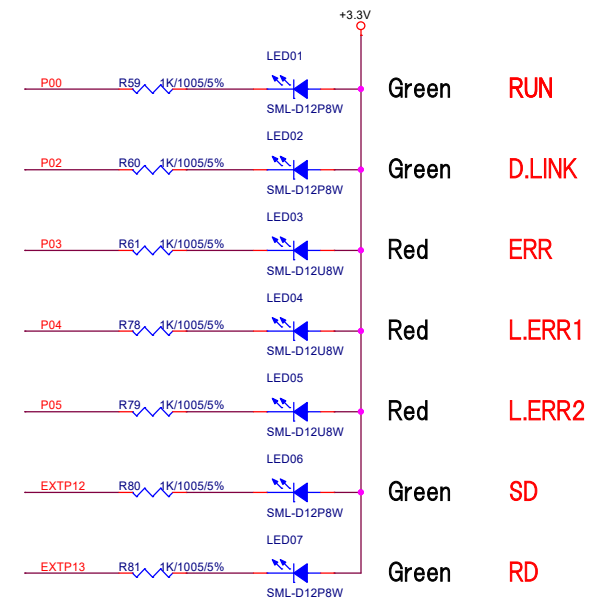
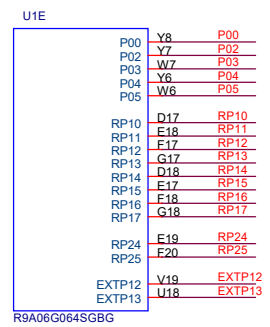
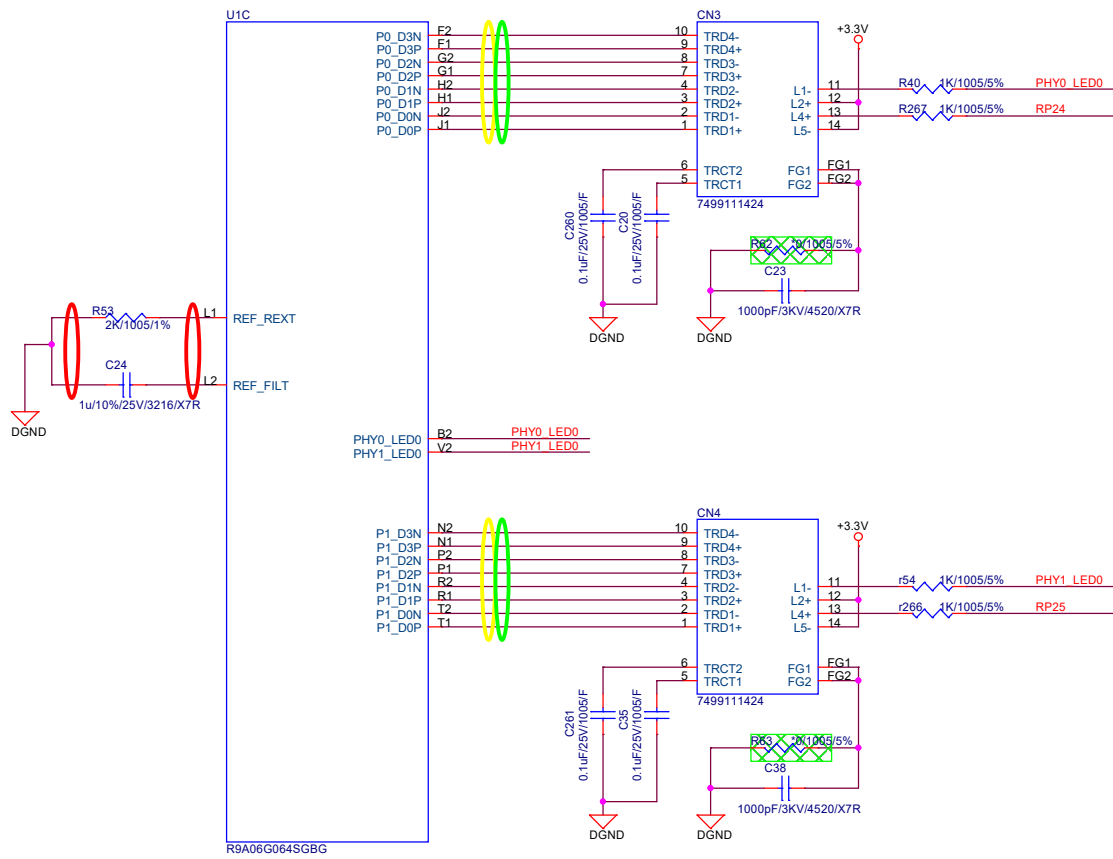

Station/IP

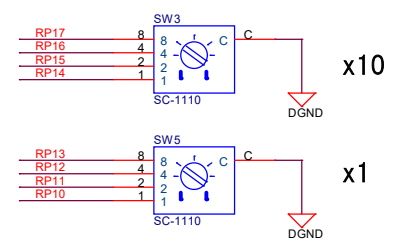

CC-Link IE	
Title	SBEV-RIN32M4CL3
Size	Document Number
A3	301251001
Date:	Tuesday, June 29, 2021
Sheet	6 of 24
Rev	1.00

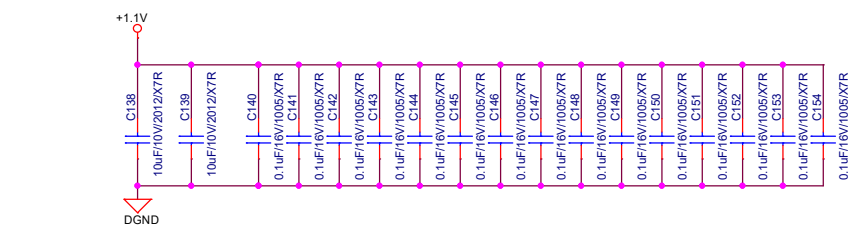
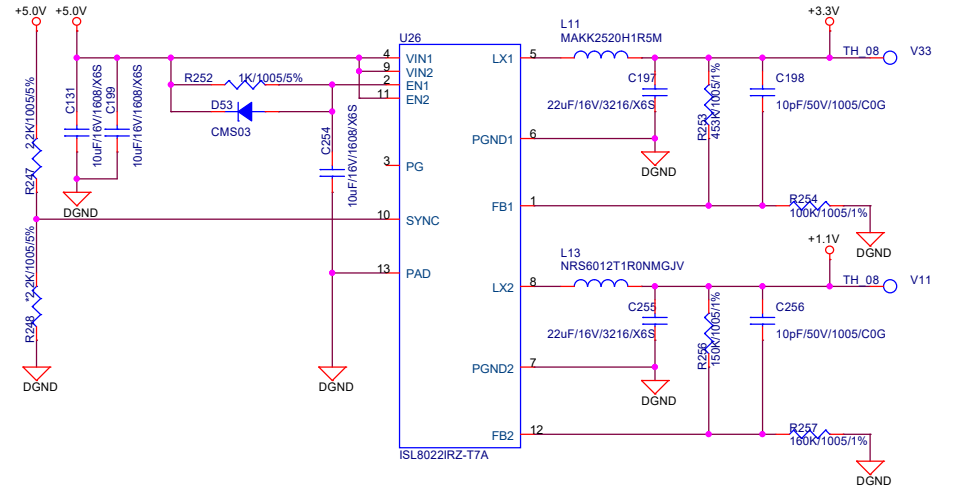
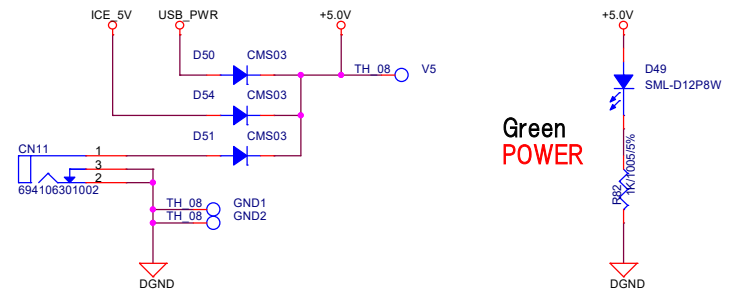
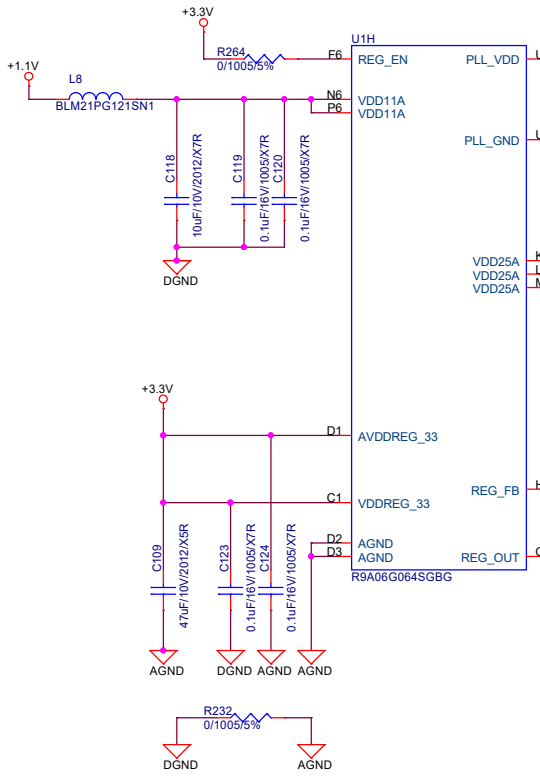
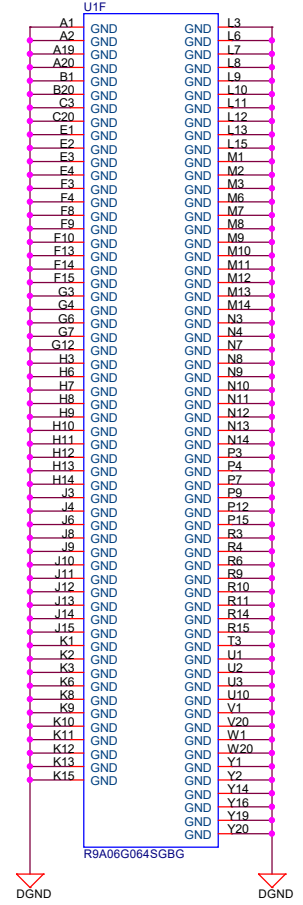
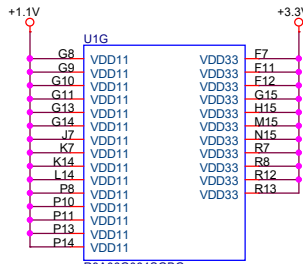

Power		
Title	SBEV-RIN32M4CL3	
Size	Document Number	Rev
A3	301251001	1.00
Date:	Tuesday, June 29, 2021	Sheet 7 of 24